

## FACTORY JACKETED AND INSULATED STORAGE TANKS

These A. O. Smith storage tanks are designed for storing potable water. Fitting locations are designed to meet the needs of normal installations plus those for the A. O. Smith Cer-Temp 80® and Shure-Temp piping methods.

### FEATURES

**MEETS ASHRAE/IESNA 90.1-2004.**

A. O. Smith storage tanks are ideal for use with gas-fired copper heat exchanger equipment for storage of any potable water at temperatures up to 180°F.

**GLASS-LINED TANK** - Alkaline borosilicate composition permanently fused to steel by firing at a temperature of 1600°F, providing years of corrosion protection and dependable use.

**HEAVY GAUGE STEEL JACKET** - With baked enamel finish.

**THREADED OPENINGS** - All tanks furnished with threaded openings for thermometer, relief valve, 2" recirculation lines, tankstat, and drain valve.

#### **TJ-80S, TJ-80A, TJV-120M and TJV-120A**

- Fits through 30" door
- Magnesium anode for anti-corrosion protection

**TJ-80A** • 80 gallons • exceeds ASHRAE requirements • saves fuel, helps reduce standby heat loss • 160 psi ASME standard working pressure.

**TJV-120A** • 119 gallons • exceeds ASHRAE requirements • saves fuel, helps reduce standby heat loss • 160 psi ASME standard working pressure.

**TJ-80S** • 80 gallons • exceeds ASHRAE requirements • 160 psi working pressure.

**TJV-120M** • 119 gallons • exceeds ASHRAE requirements • 160 psi working pressure.

#### *OPTIONS*

Perfectly balanced manifold kits (120 gallon models) allow installation where 240 to 480 gallons of stored water is required.

#### **TJV-200-M - 175 GALLONS**

- 160 psi ASME standard working pressure
- 2" foam insulation
- Handhole cleanout (Standard)
- Fits through 33" door
- Storage is downsized to 175 gallons for a 32" x 77" envelope for space restrictive installations. Model TJV-200 is available with 200 gallons of storage
- Magnesium anodes for extra corrosion protection.

#### **5 YEAR WARRANTY**

If the tank should leak any time during the first 5 years, under the terms of the warranty, A. O. Smith will repair or replace the tank. Installation, labor, handling and local delivery are extra. For complete information, consult the written warranty or contact A. O. Smith.

## MODELS TJ-80S, TJ-80A TJV-120A, TJV-120M & TJV-200M



120 Gallon Model



**ASME**  
(FOR SELECT MODELS)

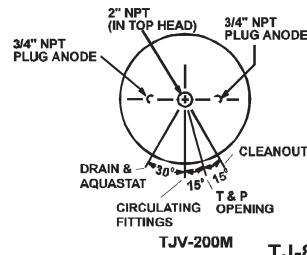
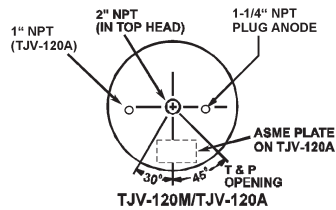
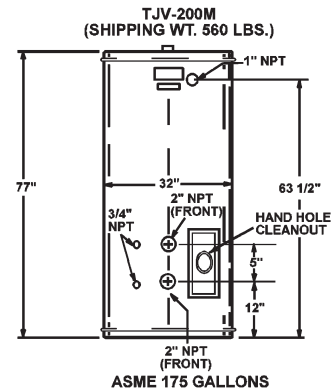
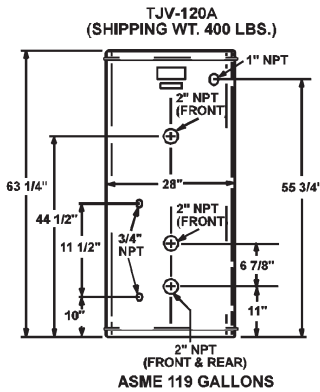
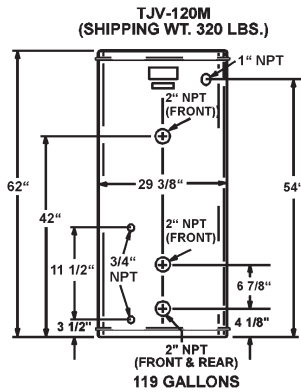

TJ-80A

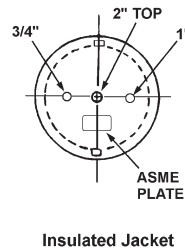
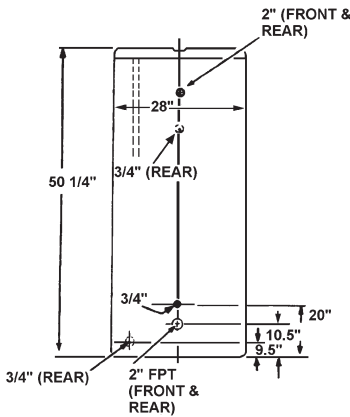

TJ-80S

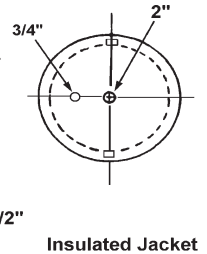
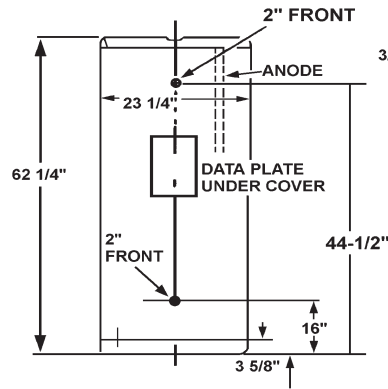

FLOOR SPACE REQUIREMENTS

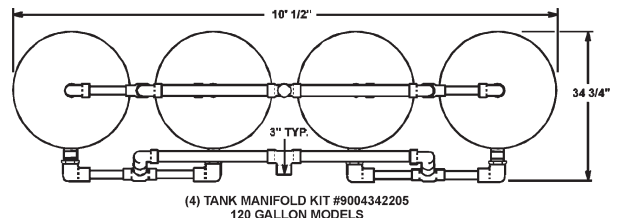
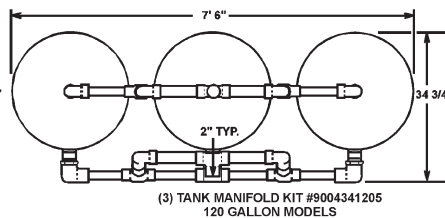
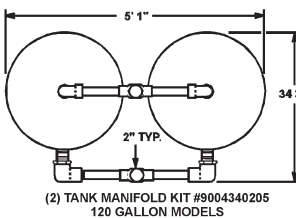

SUGGESTED SPECIFICATION

Storage tank shall be A. O. SMITH glass-lined storage tank. Tank shall be \_\_\_\_\_" x \_\_\_\_\_" and have a nominal capacity of \_\_\_\_ gallons. Tank(s) shall have threaded openings as shown on drawings. Interior of tank(s) shall be glasslined with an alkaline borosilicate composition which has been fused to the steel by firing at a temperature of 1600°F. Glass coating shall be continuous over the entire inner surface of the tank. Outer jacket shall have a baked enamel finish. Foam insulation to meet or exceed ASHRAE 90.1-2004 efficiency requirements. Cathodic protection shall be provided. Tank shall have a working pressure of \_\_\_\_ psi. Tank shall have a five year limited warranty as outlined in the written warranty.