

CONSERVATIONIST® COMMERCIAL BOILERS

Energy Saving Product

82% THERMAL EFFICIENCY*

FEATURES

COMPLIANCE – These models meet or exceed the thermal efficiency and standby loss requirements of the U.S. Department of Energy and current edition ASHRAE/IESNA 90.1.

ALL NON-FERROUS WATERWAYS – All castings are made of Bronze or Brass. All water tubes are made from copper. Brazed joints or flare union construction make the heater immune to the effects of thermal shock and thermal cycling. A great boiler for domestic hot water supply systems.

EFFICIENT COPPER COIL COMBUSTION CHAMBER – The combustion chamber is a heat exchanger formed from a two passage coil of tightly wound continuous copper tube. Water circulating through this coil surrounds the main burner and captures the radiant heat. A wrap of insulation on the outside of the coil retains the heat captured by the circulating water.

COPPER HEAT EXCHANGER – Directly above the coil and the main burner is a compact, horizontal, copper fin tube heat exchanger. The flue gases must pass through this efficient heat exchanger before leaving the boiler. This unique Burkay coil and heat exchanger design provide maximum heat transfer and proven field durability.

BURKAY BURNER MAXIMIZES EFFICIENCY – The patented Burkay burner uses primary air injection at up to 72 individual orifices plus secondary entrainment of air. Approved for installation on combustible floors as shipped from factory.

GAS VALVES – Slow opening redundant gas valves ensure smooth light-off without flame roll-out or pilot outage.

THERMAL BALANCER – Patented pump delay system that allows boiler and pump to run simultaneously but delays pump shut off at end of heating cycle to remove usable heat from the heat exchanger and reduce the scale forming tendencies of motionless hot water.

AUTOMATIC SAFETY CONTROLS AND ELECTRONIC IGNITION – Proven pilot ignition system provides flame failure response in under one (1) second. Redundant high limit controls and gas valves assure safe shutoff in the event of overheating or flame failure. Requires 120V 60Hz, maximum inlet gas pressure of 14" WC and activation of heater by external temperature control.

OPTIONAL POWERED VENT HOOD – for sidewall venting.

WORKING PRESSURE – ASME approved, hydrostatically tested and certified for 160 psi.

LIMITED WARRANTY OUTLINE – Consult written warranty or A. O. Smith.

*Except model HW-399 is 81%.

HW-300 THRU HW-670

HW - INDOOR
INSTALLATION
ONLY



FM
HW MODELS
CERTIFICATION & APPROVAL



Domestic Hot Water Supply Boilers

NOTE: TOP MANIFOLD HAS EXTRA OPENINGS FOR THERMOMETER (3/4") AND RELIEF VALVE (1") (HW-520 AND -670 ONLY)

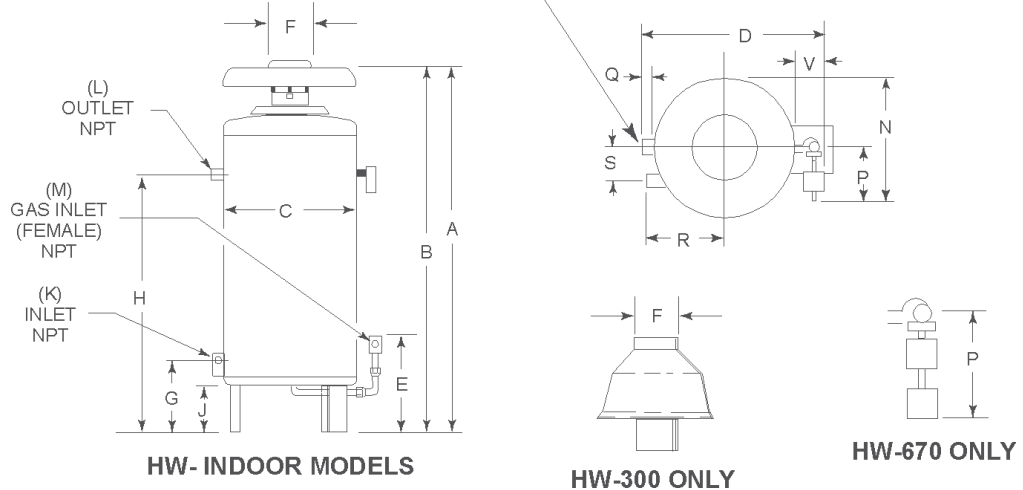

ALL DIMENSIONS IN INCHES

Models	A	B	C	D	E	F	G	H	J	K	L	M	N	P	Q	R	S	V	Approx. Ship. Wt. Lbs.
HW-300	65	43 1/4	25 1/4	29 5/8	16 1/2	8	12	36	9	1 1/4	1 1/4	3/4	26 5/8	14	1	10 1/8	5 3/8	5	240
HW-399	57 1/8	45 1/8	27	31 1/2	16 3/4	10	12	38 3/4	9	1 1/2	1 1/2	1	27 1/2	14	1	11 1/4	5 1/2	5	291
HW-420	57 1/8	45 1/8	27	31 1/2	16 3/4	10	12	38 3/4	9	1 1/2	1 1/2	1	27 1/2	14	1	11 1/4	5 1/2	5	291
HW-520	68 5/16	56 1/4	27	36 1/2	18	10	12	46 1/2	9	2	2	1 1/4	24 1/2	11	3 1/2	12	5 3/4	7	361
HW-670	67	56 1/4	27	38 1/4	17 3/4	12	12	46 1/2	9	2	2	1 1/4	26 3/4	13 1/4	3 1/2	12	5 3/4	7	361

Model	Input Rating AGA BTUH Natural and Propane Gas	GPH	Temperature Rise - Degrees F													
			20	30	40	50	60	70	80	90	100	110	120	130	140	
HW-300	300,000	GPH	1,484	989	742	594	495	424	371	330	297	270	247	228	212	
HW-399	399,000	GPH	1,938	1,292	969	775	646	554	484	431	388	352	323	298	277	
HW-420	420,000	GPH	2,067	1,378	1,034	827	689	591	517	459	413	376	345	318	295	
HW-520	520,000	GPH	2,575	1,717	1,288	1,030	858	736	644	572	515	468	429	396	368	
HW-670 Nat.	660,000	GPH	3,264	2,176	1,632	1,306	1,088	933	816	725	653	593	544	502	466	
HW-670 LP	670,000	GPH	3,217	2,145	1,609	1,287	1,072	919	804	715	643	585	536	495	460	

SUGGESTED SPECIFICATION

Boiler(s) for hot water supply purposes shall be Model(s) No. _____ as manufactured by A. O. Smith or an approved equal. Boiler(s) shall be gas-fired, and design certified by an ANSI approved/accredited independent rating laboratory, capable of supplying ____ gph at 100°F temperature rise equipped to burn _____ gas, with input rating of ____ BTU/hr. and bearing the ASME code symbol. Boiler(s) shall be up flow type having all non-ferrous waterways, and employing a copper finned heat exchanger and a tightly wound copper coil combustion chamber with 160 psi working pressure rating. Boiler(s) shall be equipped with an electric gas valve of the step-opening type, an adjustable limit control which will break the electric circuit on temperature rise, intermittent ignition with one (1) second shutdown in the event of pilot flame failure, a gas pressure regulator properly set for the gas to be supplied, and a coil limit switch for shut off in event of excessive water temperature, a certified draft diverter and a fully illustrated instruction manual. Certified for combustible flooring. Outer jacket shall be of baked enamel finish. The coil, heat exchanger and burner shall have a five year limited warranty as outlined in the written warranty.

For Technical Information and Automated Fax Service, call 800-527-1953. A. O. Smith Corporation reserves the right to make product changes or improvements without prior notice.