

POWERED BURNER MODELS LIGHT-DUTY COMMERCIAL GAS WATER HEATERS FEATURES

These BTP models are equipped with powered gas, non-forced-draft burners requiring a negative draft. With 75 and 86 gallon storage capacities and inputs from 140,000 to as high as 370,000 BTUs, they are suitable for commercial applications. A. O. Smith provides a FREE professional start-up that is required on the BTP models.

POWERED GAS BURNER

- Electronic flame safeguard control with direct spark ignition
- Redundant gas valves for added safety
- Power gas burner requires 120V, 60Hz service
- Non-forced-draft burner; negative draft required in vent piping

FULLY AUTOMATIC CONTROLS WITH SAFETY SHUTOFF

- High temperature limit control (manual reset)
- Dual thermostats for accurate temperature control 120°F – 180°F

PERMAGLAS® ULTRA COAT™ GLASS LINING

- Exclusive process provides superior protection against corrosion
- CoreGard™ anode rods with stainless steel core provide additional corrosion protection

BAROMETRIC DRAFT DAMPER

- Ensures proper draft for maximum efficiency

HANDHOLE CLEANOUT

- Allows easy access to tank interior for cleaning

CSA CERTIFIED AND ASME RATED T&P RELIEF VALVE

80% THERMAL EFFICIENCY

MAXIMUM HYDROSTATIC WORKING PRESSURE: 160 PSI

FACTORY START-UP INCLUDED

- Required for activating warranty and assuring maximum performance. Contact your local sales representative or Authorized Start-Up Agent to arrange a FREE Certified Start-Up.

FLAME INSPECTION PORT OPENING

MOUNTED ON RUGGED CHANNEL IRON SKIDS

MUST BE INSTALLED ON NON-COMBUSTIBLE SURFACE CODES AND STANDARDS

- Design-certified by UL (Underwriters Laboratories) International, according to ANSZ21.10.3- CSA4.3 standards governing storage-type water heaters
- Meets or exceeds the Thermal Efficiency and/or Standby Loss Requirements of the U. S. Department of Energy and Current Edition of ASHRAE/IESNA 90.1

THREE-YEAR LIMITED TANK WARRANTY

- For complete information, consult written warranty or contact A. O. Smith

OPTIONS

- ASME tank construction
- National Board Registration on ASME models
- Illinois School Code on BTP-199, BTP-370
- Low-water cutoff
- 5-year or 10-year extended limited warranty

MODELS BTP-139/A through BTP-370/A



ASME



GAS-FIRED



CAPACITY, INPUT AND RECOVERY

Model Number	BTU Input Per Hour	Gallons or Litres	Tank Size	GPH or LPH	Recovery—Gallons Per Hour At °F Temperature Rise			Maximum Amperes 120V, 60 Hz, 1
					40°F	100°F	140°F	
					22°C	56°C	78°C	
BTP-139/A	140,000	U.S. Gallons	81	GPH	0	136	97	5
		Litres	306.6	LPH	0.0	514.8	367.1	
BTP-199/A	199,000	U.S. Gallons	81	GPH	0	193	138	5
		Litres	306.6	LPH	0.0	730.4	521.7	
BTP-270/A	270,000	U.S. Gallons	81	GPH	0	262	187	5
		Litres	306.6	LPH	0.0	991	707.8	
BTP-370/A	370,000	U.S. Gallons	81	GPH	0	359	256	5
		Litres	306.6	LPH	0.0	1358	970	

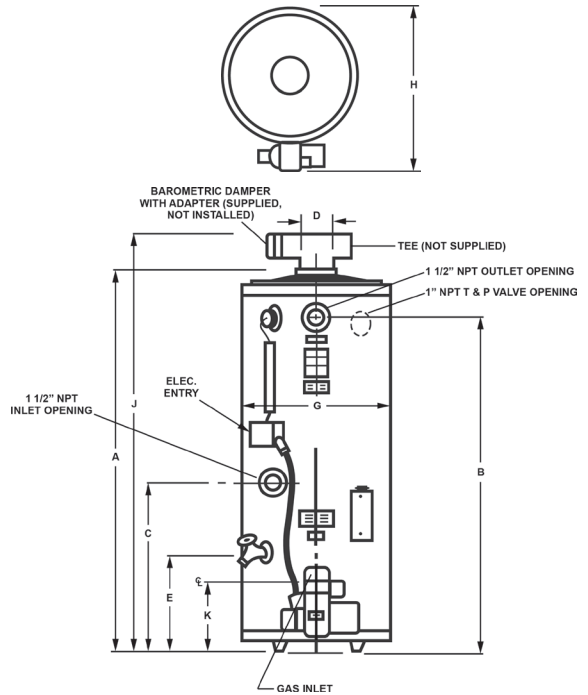

DIMENSIONS AND SHIPPING WEIGHTS

Model Number	Inches or Litres	Dimensions								Gas	Shipping Weight			
		A	B	C	D	E	G	H	J		Standard	ASME	In	Out
BTP-139/A	Inches	74.75	65	26-3/4	6	21-3/8	27-3/4	38	85-1/4	1/2	556 lbs.	658 lbs.	1-1/2	1-1/2
	cm	189.9	165.1	67.9	15.2	54.3	70.5	96.5	216.5	1.3	252.7 kg	299.1 kg	3.8	3.8
BTP-199/A	Inches	74-3/4	65	26-3/4	6	21-3/8	27-3/4	38	85-1/4	1/2	545 lbs.	635 lbs.	1-1/2	1-1/2
	cm	189.9	165.1	67.9	15.2	54.3	70.5	96.5	216.5	1.3	247.7 kg	288 kg	3.8	3.8
BTP-270/A	Inches	74-3/4	65	26-3/4	6	21-3/8	27-3/4	38	85-1/4	3/4	547 lbs.	632 lbs.	1-1/2	1-1/2
	cm	189.9	165.1	67.9	15.2	54.3	70.5	96.5	216.5	1.9	248.6 kg	287.3 kg	3.8	3.8
BTP-370/A	Inches	74-3/4	65	26-3/4	6	21-3/8	27-3/4	38	85-1/4	3/4	547 lbs.	632 lbs.	1-1/2	1-1/2
	cm	189.9	165.1	67.9	15.2	54.3	70.5	96.5	216.5	1.9	248.6 kg	287.3 kg	3.8	3.8

SUGGESTED SPECIFICATION

(Natural or Propane) gas water heater(s) shall be A. O. Smith Model BTP _____ with a strong capacity of _____ gallons, an input rating of _____ BTUs per hour, a recovery capacity of _____ GPH at 100°F temperature rise and a maximum hydrostatic working pressure of 160 PSI. Heater(s) shall meet or exceed the thermal efficiency and/or standby loss requirements of the U. S. Department of Energy and current edition of ASHRAE/IESNA 90.1. Water heater(s) shall have glass-lined tank, protected against electrolytic corrosion by multiple factory-installed anode rods. Other standard equipment shall include: 1) Powered gas burner with redundant main gas valves, electronic ignition, automatic pilot gas valves, gas pressure regulator, and flame inspection port; 2) Handhole cleanout; 3) High temperature limit control; 4) Dual thermostat for accurate temperature control; 5) CSA Certified and ASME rated T&P relief valve.

Controls shall include a Fenwal OSI to provide direct spark ignition and flame monitoring. A prepurge of 30 seconds minimum shall be provided. A trial for ignition period of 5 seconds, after which if the flame is not proved or lost during the running cycle, the system will lock out.

Heater(s) tank shall have a 3-year (or extended 5 or 10 year limited) warranty against corrosion as outlined in the warranty.