

FEATURES

The BPD-75 tank-type commercial gas water heater is intended for light-duty applications such as small office buildings and duplex apartment homes. The BPD-75 features a power direct-vent design, with a factory-installed blower. The blower permits sealed combustion direct-vent operation, with separate venting and air intake runs from outside the structure. The BPD-75 offers installation versatility by allowing venting and intake runs up to 50 feet, using 3" Schedule 40 PVC pipe.

The power direct-vent design also eliminates the potential for performance and safety problems caused by negative air pressure, a problem found in many commercial applications with inadequate indoor ventilation.

DYNACLEAN™ II AUTOMATIC SEDIMENT-CLEANING SYSTEM

- Specially designed dip tube directs incoming cold water to create turbulence in the tank to reduce lime and sediment buildup
- Prolongs tank life, maintains high energy-efficiency, maximizes hot water output

PERMAGLAS® GLASS-LINED TANK

- Glass lining and anode rod protect steel tank from corrosion

QUIET MODULAR BLOWER

- Built-in safety device prevents pilot or main burner operation if blower is not operating
- Blower has 110/120V electrical system, with maximum 2-amp draw

DURABLE BRASS DRAIN VALVE

FACTORY-INSTALLED

- CSA CERTIFIED AND ASME RATED T&P RELIEF VALVE

MAXIMUM HYDROSTATIC WORKING PRESSURE 150 PSI

80% THERMAL EFFICIENCY

STANDARDS

- Design-certified by CSA International, according to ANSI Z21.10.3 - CSA 4.3 standards governing storage-type water heaters
- Meets or exceeds the thermal efficiency and/or standby loss requirements of the U.S. Department of Energy and current edition of ASHRAE/IESNA 90.1

WARRANTY

- Three-year limited tank warranty
- Consult written warranty shipped with water heater or contact A.O. Smith Water Heaters

MODELS BPD-75



GAS-FIRED



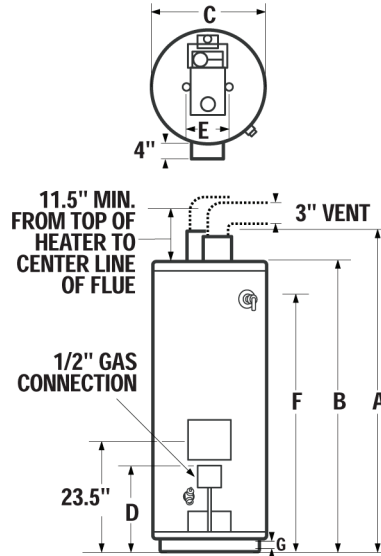

MODEL NUMBER	GALLON CAPACITY	BTU INPUT PER HOUR	FIRST HOUR RATING 100°F RISE	RECOVERY – GALLONS PER HOUR AT °F TEMPERATURE RISE		
				40°	100°	140°
BPD-75 Natural	75	70,000	117	161	64	46
BPD-75 Propane	75	65,000	112	148	59	42

DIMENSIONS AND WEIGHT

MODEL NUMBER	DIMENSIONS IN INCHES							CONNECTIONS		APPROX. SHIPPING WEIGHT (lbs.0)
	A	B	C	D	E	F	G	GAS	WATER	
BPD-75	69 5/8	61 5/8	26	16 5/8	8	54	2	1/2"	3/4"	352

SUGGESTED SPECIFICATION

Water Heater(s) shall be model BPD-75 as manufactured by A.O. Smith. Water heater(s) shall be of glass-lined design, and gas-fired, equipped to burn _____ gas and design certified by Underwriters Laboratories under Volume III tests for commercial heaters for delivery of 180°F water, and meet or exceed the thermal efficiency and/or standby loss requirements of the U.S. Department of Energy and current edition of ASHRAE/IESNA 90.1. Heaters shall have an input rating of _____ and a recovery rating of _____ GPH at a temperature rise of 100°F with a storage capacity of 75 gallons.

Unit(s) shall be direct-vent design, with an automatic blower-powered, two-pipe air intake and exhaust system communicating directly with the outside of the building. The blower shall have a safety device that will not allow the operation of the main burners unless the blower is in operation. Unit(s) shall have a combustion air passage that is internal to the outer jacket of the water heater other than the intake and exhaust connections at the top of the water heater.

Heater tank shall have a 3-year limited warranty against corrosion or sediment buildup as outlined in the written warranty. Fully illustrated instruction manual to be included.